

Technical Brochure - High Efficiency Series

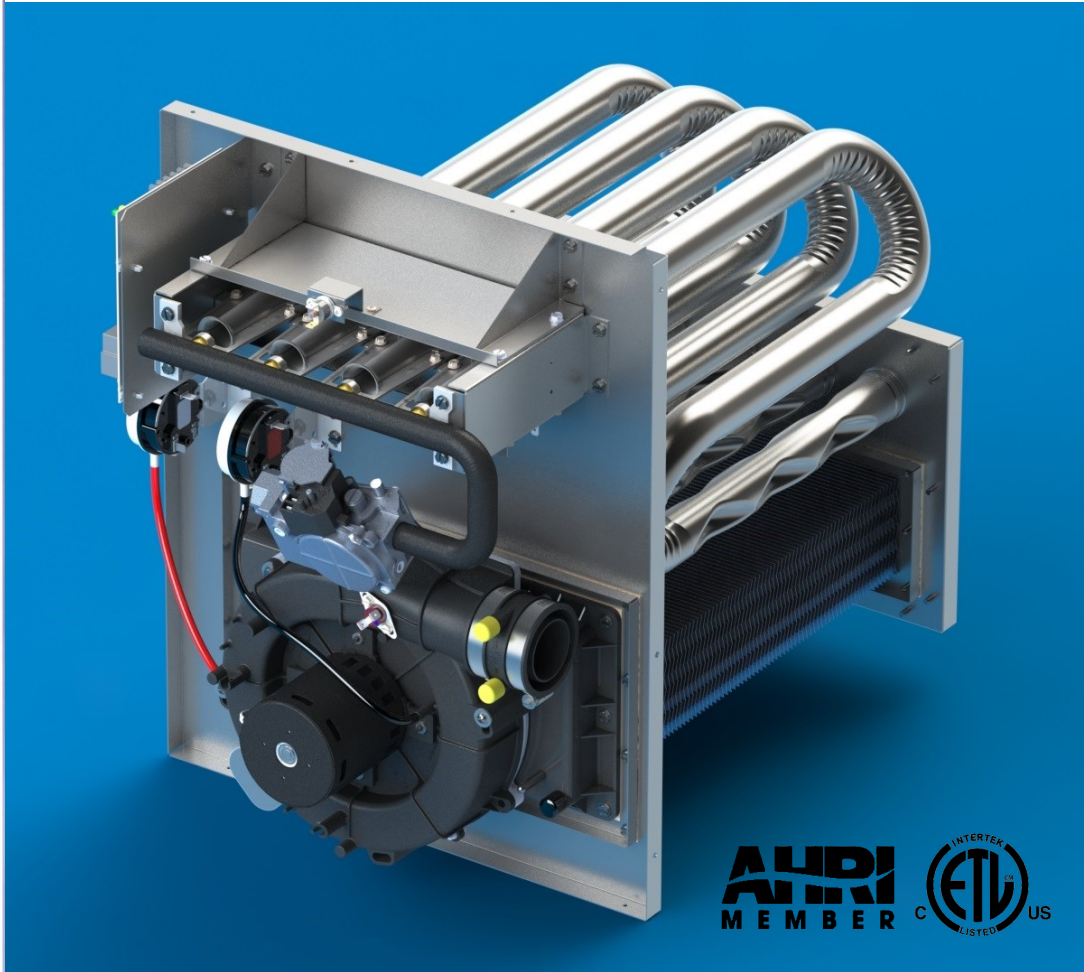

Beckett Gas, Inc.  
Commercial Systems Division

HEG Series High Efficiency Duct Furnace



[www.beckettgas.com](http://www.beckettgas.com)



Designed and built in the USA.

With the performance you need  
and the quality you trust.

## Beckett Gas High Efficiency Duct Furnaces

### On-Time Delivery

Beckett Gas consistently out performs our customers expectations for on-time delivery

### Customer Service

Our customer service team is knowledgeable about this product, its availability, and can work with your buyers to plan a smooth transition into production

### Engineering Support

Five ASGE-certified gas engineers with more than 100 years experience across multiple disciplines ready to assist you

Commercial Systems Division  
21819 Royalton Road  
Strongsville, Ohio 44149

[www.beckettgas.com](http://www.beckettgas.com)

### FEATURES AND BENEFITS

This heat module series provides application flexibility and the latest tubular heat exchanger technology.

- **Recognized under ANSI Z83.8 by ETL**

- **Higher efficiency, lower internal static pressure**

- **Extended operational life**

Tubes expand into collector box so welding is eliminated.

- **Accommodate wide range of gas inputs**

From 150,000 to 400,000 Btuh, natural or propane gases.

- **Advanced Heat Exchanger:** Made of 29-4C stainless steel. Secondary condensing coil for maximum strength and corrosion resistance. Primary is made of 409 stainless steel tubes which are expanded to the collector box. No welding is used in the manufacturing process. This makes Beckett 90% heat exchanger highly resistant to thermal fatigue and other stresses caused by repeated heating and cooling.

- **Condensing, 93%+ combustion efficiency for an outdoor rooftop unit..**

- **Horizontal or vertical indoor or outdoor installation**

- **Applicable for up to 100% outside air**

- **Engineered to deliver 90%+ combustion efficiency for maximum energy savings and comfort**

- **Pre-wired control package**

Includes long-life draft inducer, ignition control, gas valve, spark igniter, flame sensor, air switch and flame rollout switches - opening provided for disc-type high limit. 115V/ 60Hz.

### CONTROL OPTIONS

- **NS** - Single-stage operation with single-stage valve and draft inducer.

- **TS**- Two-stage gas valve with single-speed draft inducer operation (high fire 100%, low fire 55%).

- **MD** - Modulating 5 :1.

# HEG Series

Beckett Gas, Inc.  
Commercial Systems Division

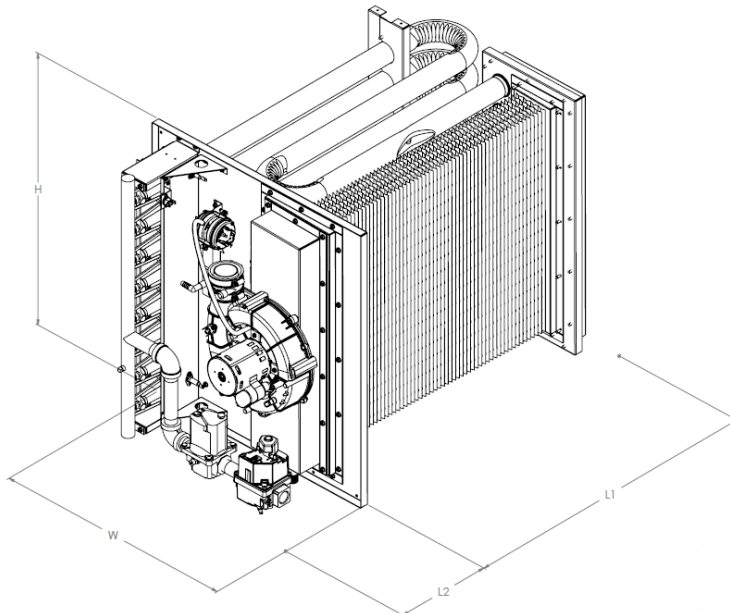

Model No.	Input (BTU)	Output (BTU)	Rise (°F)		Air flow (CFM)		Dimensions (Inches)			
			Min	Max	Max	Min	L <sub>1</sub>	H	W	L <sub>2</sub>
HEG400	400,000	372,000	20	100	17,222	3,444	28.25	44.75	22.45	8.5
HEG350	350,000	325,500	20	100	15,069	3,014	28.25	44.75	22.45	8.5
HEG300	300,000	279,000	20	100	12,917	2,583	28.25	36.5	22.45	8.5
HEG250	250,000	232,500	20	100	10,764	2,153	28.25	36.5	22.45	8.5
HEG200	200,000	186,000	20	100	8,611	1,722	28.25	25.5	22.45	8.5
HEG150	150,000	139,500	20	100	6,458	1,292	28.25	25.5	22.45	8.5

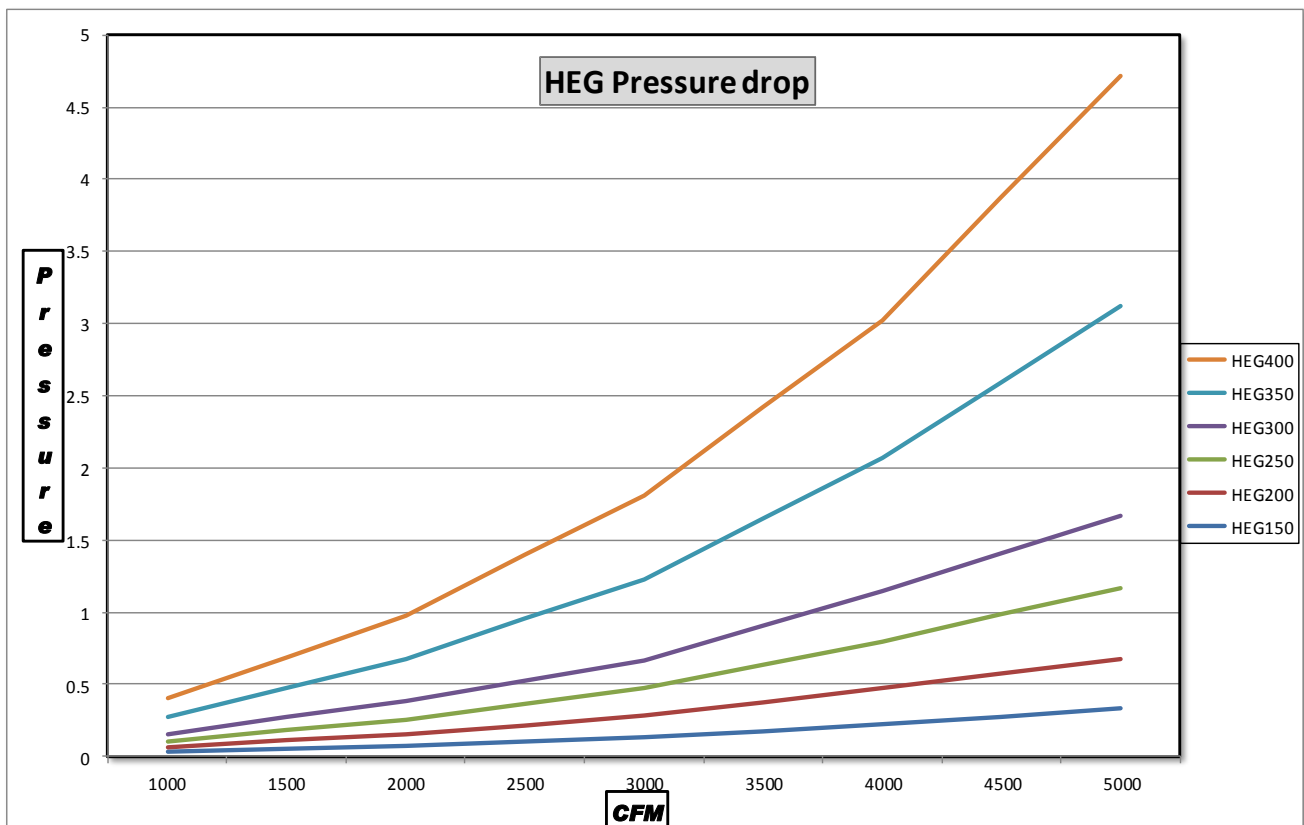





**A dedication to great work leads to great growth.  
Our history is proof of that.**

Beckett Gas, Inc. was formed in 1988 as part of a family of Beckett companies serving the HVAC market. Initially, our company was created to service the furnace and boiler markets with ported linear style gas burners. Today, through strategic acquisitions and aggressive research and development, we continue to grow - both expanding our product portfolio and the markets we serve. All the while, we continue to provide our customers the utmost in quality products and unsurpassed customer service. Beyond the customer relationships we maintain, our state-of-the-art manufacturing facility is another strong testament to our growth. Our commitment to you is to keep developing products that raise the industry bar for innovation and quality.

Looking for design input? Engineering support? Let us know how we can help with your next project. Contact your Beckett Gas representative at [bgimain@beckettcorp.com](mailto:bgimain@beckettcorp.com) or call 440.327.3141/800.332.4244.



**Commercial Systems Division  
21819 Royalton Road  
Strongsville, OH 44149**

**[www.beckettgas.com](http://www.beckettgas.com)**

